

CERAMIC BAND HEATERS

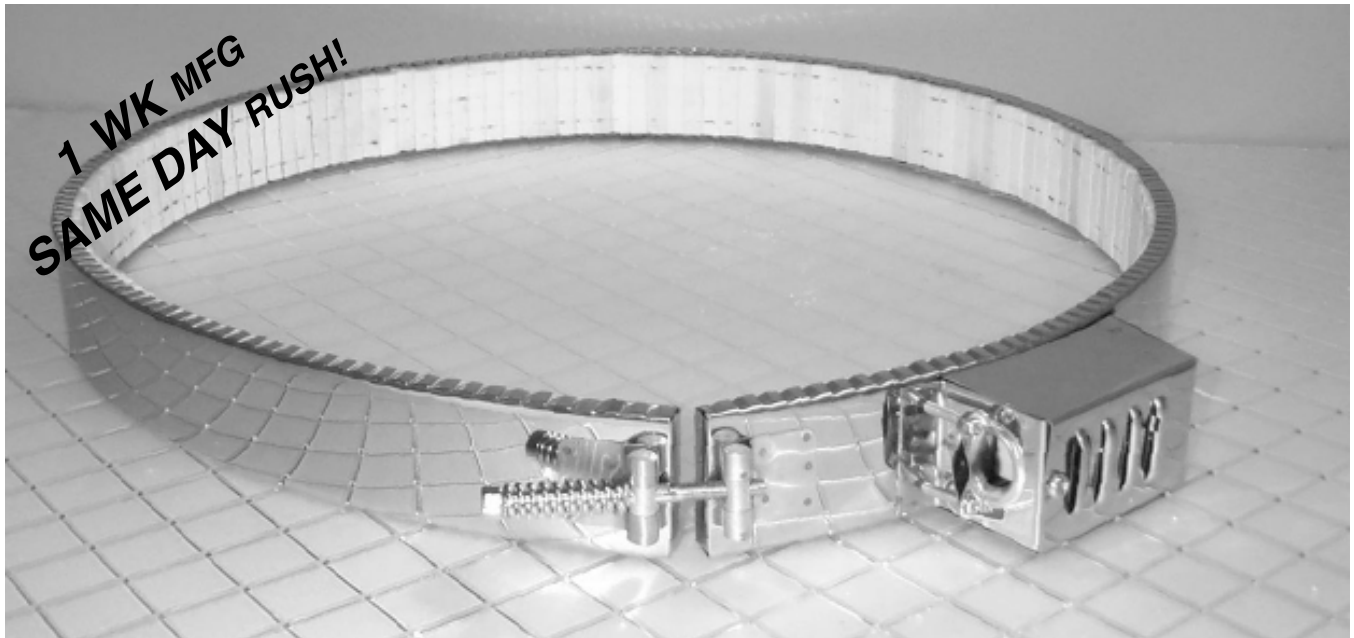

**1 WK MFG
SAME DAY RUSH!**

CERAMIC BAND HEATER TERMINATIONS

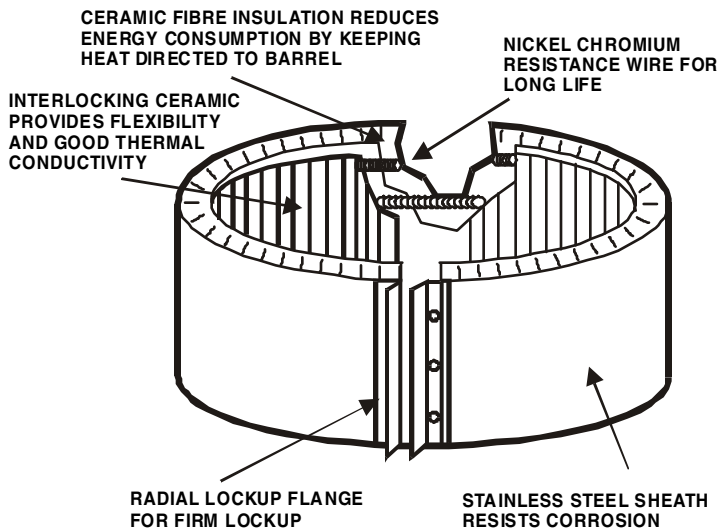

STANDARD FEATURES

- STAINLESS STEEL EXTERIOR
- HIGH TEMP INSULATION
- POST TERMINALS
- BUILT IN STRAP

OPTIONAL FEATURES

- LEADS - METAL CONDUIT
- LEADS - SS OVERBRAID
- HOLES, CUTOUTS
- SEPARATE STRAP
- TERMINAL BOX
- PARTIAL COVERAGE
- BARREL NUT/SRING LOADED
- AIR COOLING PERFORATIONS
- EUROPEAN CONNECTOR

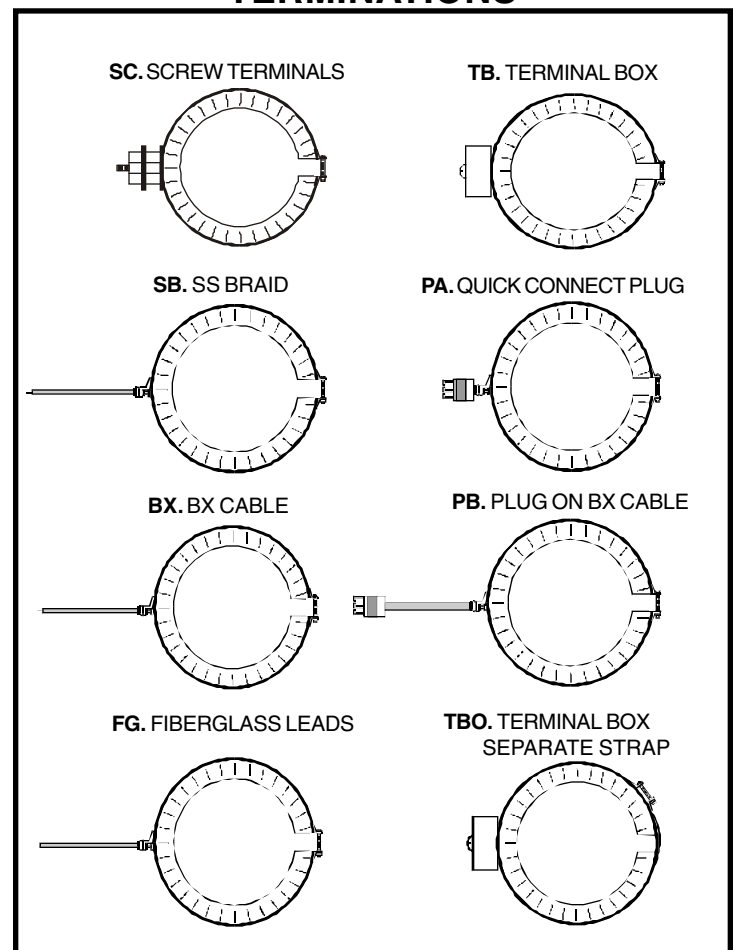

CERAMIC BAND WITH BLOWER

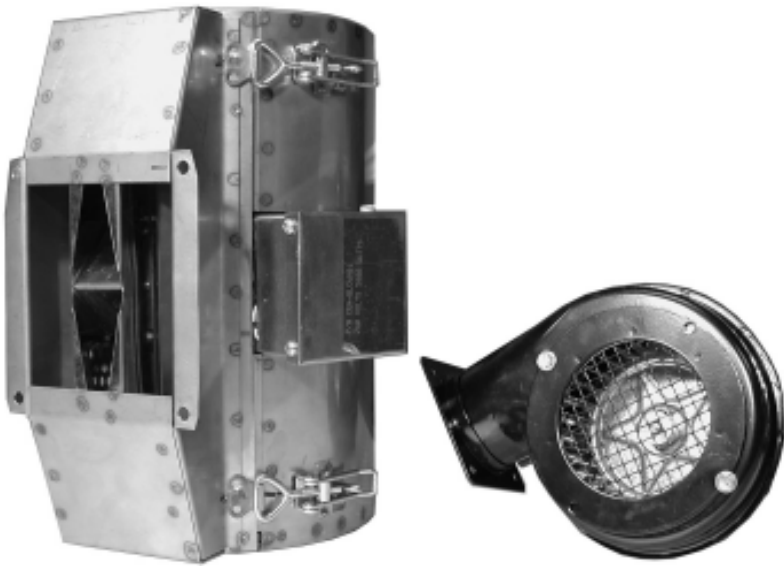

SHROUD WITH AIR BAFFLES TO
DIRECT AIR FLOW
HINGED CONSTRUCTION FOR
EASY ACCESS TO REPLACE-
ABLE HEATERS



STYLE 1 - INTERNAL CERAMIC
HEATER WITH PERFORATED
SHELL FOR FAST COOLING



STYLE 2 - INTERNAL CERAMIC
HEATER WITH PERFORATED
SHELL FOR FAST COOLING