

# MICA STRIP HEATER

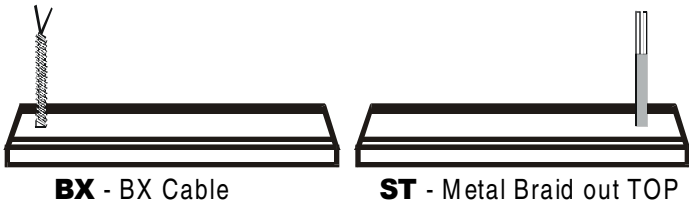
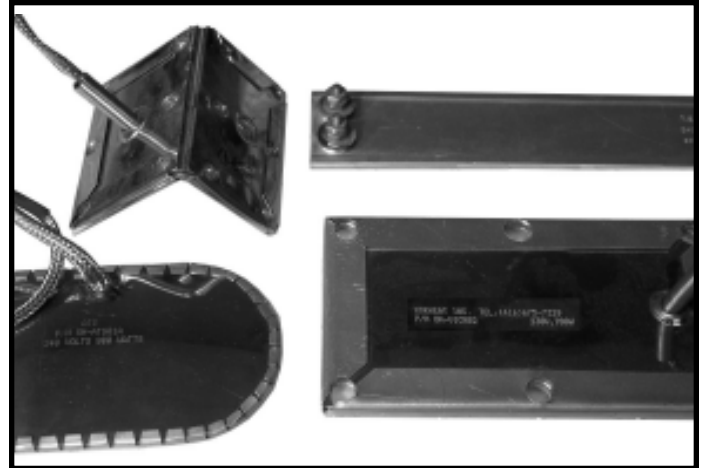
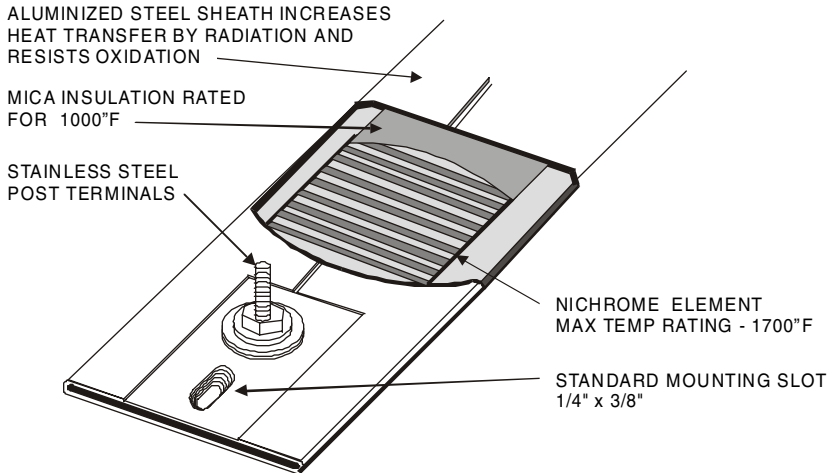

## SPECIFICATIONS

|                      |        |
|----------------------|--------|
| WIDTH TOLERANCE      | 1/16"  |
| LENGTH TOLERANCE     | 1/8"   |
| MAXIMUM SHEATH TEMP  | 800°F  |
| TERMINAL HEIGHT      | 1/2"   |
| MAX HEATER THICKNESS | 0.180" |

MorHeat mica strip heaters provide rapid heat transfer to dies, tanks, sealing machines, hot plates or other equipment possessing flat surfaces. The construction of mica strip heaters is closely identical to the mica band heaters listed separately in this catalog.

## BUTT CASE CONSTRUCTION

Strip heaters when ordered for use in grooved platens, should be ordered with our butt-case construction. Butt-case provides the means to transfer heat efficiently through both surfaces of the heater.

## APPLICATION

Wattage should be maintained below 35W/sq. in. When surface mounted, mica strip heaters should not exceed 22W/sq. in. Proper clamping and application of strip heaters will provide long life and efficiency while offering the most cost effective heater available.