

CIRCULATION HEATERS

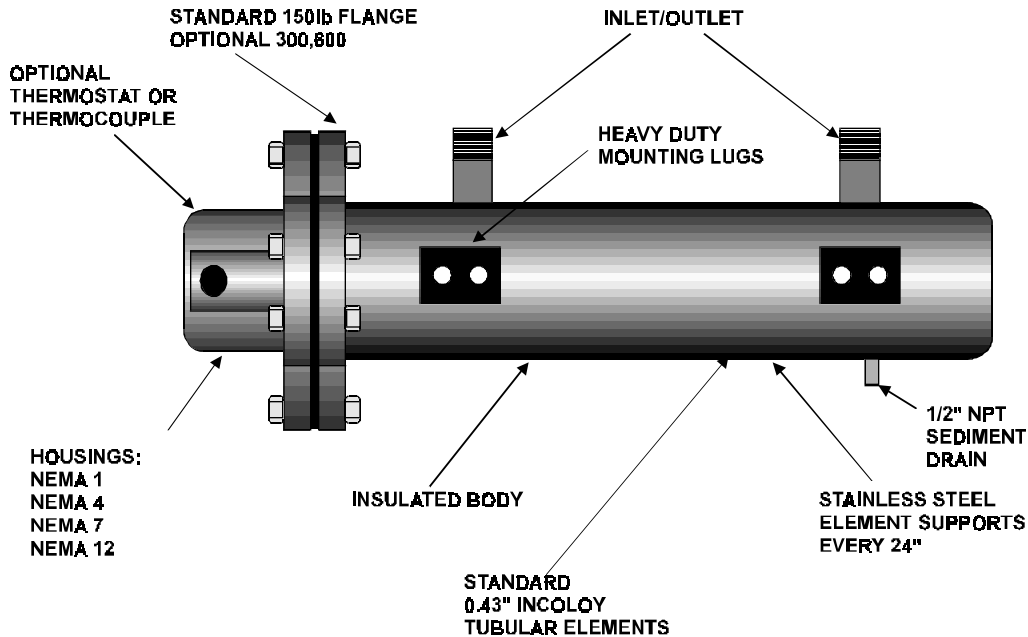

APPLICATION

MORHEAT circulation heaters are suitable for use in forced flow and natural flow heating loops where a safe, clean, reliable, and efficient heating source is required.

Virtually any liquid may be heated provided that the system design ensures that the heater vessel remains completely full of liquid when in use. Forced flow heating (with circulator pump) is mandatory when heating heavier liquids or heating liquids to high temperatures. Natural flow systems are generally limited to 'side arm' water heating applications where the heater is mounted vertically and the top of the heater is well below the minimum tank liquid level.

In gas heating applications such as heating compressed air, steam superheating, nitrogen, ammonia, etc. flow must be sufficient to ensure that maximum allowable vessel and sheath temperatures are not exceeded. MORHEAT engineers will assist in the selection of the best heater for your particular application.

SPECIFICATIONS

Watts: 0.5 to 800 KW
 Volts: 110 to 600 Volts, (50 or 60 Hz)
 Flange Size: up to 24 In. ANSI
 150 to 1200 PSI
 Flange Material: Carbon Steel, various Stainless Steel(s)
 Pressure Vessel Sizes: up to 24 Inches Pipe and Flange Size
 Pressure Vessel Material: Carbon Steel, various Stainless Steel(s)
 Overall Length - "A" dimension up to 360 Inches Sheath Materials: refer to 'Element Sheath Materials'

CONSTRUCTION

U-shaped tubular elements are mounted in a heavy flange. Elements are sheathed in copper, steel or alloy to resist chemical action with appropriate heating surface watt densities normally required. Cross flow baffles, available in some models, evenly direct flow of heavy fluids past heated surfaces to prevent local overheating and possible carbonization. The flange is welded to one end of a heavy-wall pipe or heating chamber. Also welded to the pipe are threaded inlet and outlet pipes and, at end opposite the flange, a closure with centered drain plug. Heating chamber is completely insulated and enclosed in sheet-steel housing. Terminal-wiring area is also enclosed.

ELEMENT SHEATH MATERIALS...

COPPER, STAINLESS - 321, 304, 316L, INCOLOY

OPTIONS

THERMOCOUPLE
 BUILT-IN CONTROLS
 PRESSURE SWITCH
 SPECIAL REQUEST